



A TRADITION OF EXCELLENCE



INSTRUCTION BOOK

www.wolseleygrooming.co.uk

Stockshop (L.E.) Ltd., Lodge Trading Estate, Broadclyst, Exeter EX5 3BS
Email: service@stockshop.co.uk Tel: 01392 460077 Fax: 01392 460966

Contents

1. Safety	Page 2
2. Parts	Page 3
3. Preparation and Use of your Clipper.....	Page 4
4. Air Filter	Page 6
5. Motor Overload Protection	Page 7
6. Blade Sharpening, Clipper Servicing & Repairs	Page 7
7. Frequent Clipping Questions	Page 8
8. Maintenance and Storage	Page 8
9. Disposal	Page 8

Introduction

Your Wolseley clipper has a 2 year guarantee. Please make sure that you complete and return the Guarantee Registration Card or register online at www.wolseleygrooming.co.uk within 30 days of purchase otherwise your guarantee will not be valid.

If you have any queries concerning your clipper not covered by this Instruction Book please contact our specialist in-house service department.

Wolseley Service Department Stockshop (L.E.) Ltd.

Lodge Trading Estate, Broadclyst, Exeter EX5 3BS

Email: service@stockshop.co.uk Tel: 01392 460077 Fax: 01392 460966

For information on clipping a horse please consult the Wolseley Clipping Guide.

1. Safety

Clipping animals can be dangerous and it is advised that you take all possible safety precautions. In particular:

- Keep your clipper out of the reach of children at all times.
- Never connect your clipper directly to the power source, always use a circuit breaker.
- Ensure that you have an adequate electrical supply which conforms to relevant safety standards. Never use a damp outdoor socket.
- Always switch your clipper off before connecting it to or disconnecting it from the power source.
- Disconnect your clipper whenever you are carrying out cleaning or maintenance, changing your clipper blades, or whenever your clipper is not in use.
- Regularly check your electric leads, connectors and clipper for damage. (For Servicing and Repairs please see Section 6, page 7).
- Wear protective footwear, steel capped and rubber soled, a hard hat is also advised.
- Avoid using long cable leads which you may trip over or the horse may stand on.
- Have an experienced assistant to hold the animal and to generally assist you.

2. Parts

Note: The position of the on/off switch, reset switch and air filter will depend on the model of your clipper

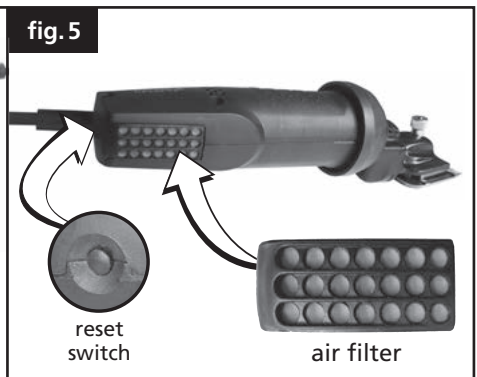
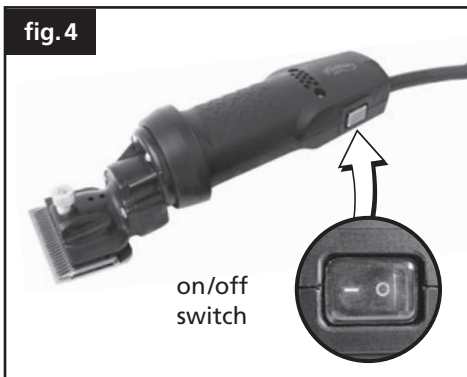
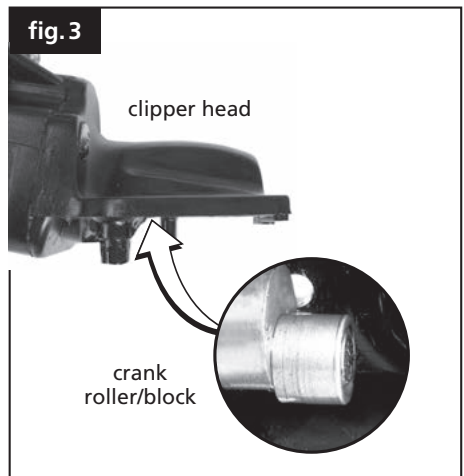
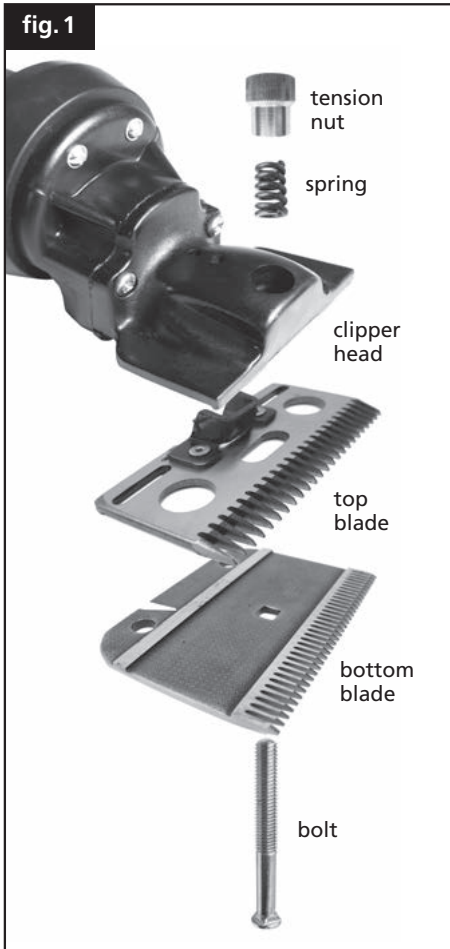

3. Preparation and Use of your Clipper

A. Choose the correct Wolseley Clipper Blades

- To achieve the best clip it is essential to choose the correct Wolseley clipper blades.
- When choosing the most appropriate blades, you must consider:-
 - (a) type of animal
 - (b) length of hair
 - (c) condition of coat
- Wolseley offer four types of clipping blades:
 - (i) **A2F Fine blades.** Clipping height 2mm. Use - veterinary surgical / freeze branding cattle.
 - (ii) **A2 Original blades.** Clipping height 2-3 mm. Use - horse / clean cattle.
 - (iii) **A6 Coarse Blades.** Clipping height 3mm. Use - horses with thick coats / cattle.
 - (iv) **A7 Extra Coarse Blades.** Clipping height 3-4mm. Use - coarse hair on cattle.
- If you are in doubt as to which Wolseley clipper blades to use we advise that you consult your Wolseley dealer for more detailed information.
- **Always use Wolseley clipper blades on your Wolseley clipper.**

B. Tensioning the Clipper Blades

- Your Wolseley clipper will arrive with the clipper blades on.
 - To tension them correctly:
 - Turn on the clipper.
 - Adjust the tension by turning the tension nut clockwise until you feel it start to tighten (see fig.6) **You will hear the motor begin to strain.**
 - Loosen the blades by turning the tension nut anti-clockwise (approximately ½ turn) until you feel the blades loosen (see fig.7). **You will hear the motor begin to run freely.**
 - Use the marker on the tension nut for a guide.
 - You are now ready to clip.
 - You may need to adjust the tensioning whilst clipping if the blades become worn or if you are clipping a thick or dirty coat. Do this by turning the tension nut anti-clockwise ¼ turn each time until the blades start to clip properly again.

fig.6

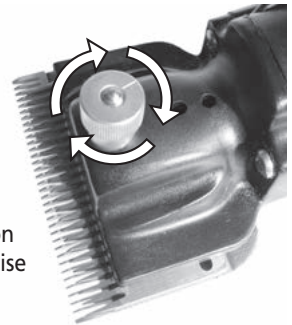

turn tension nut clockwise until tight

fig.7

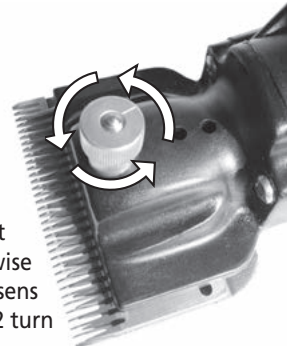

turn the tension nut anti-clockwise until it loosens (approx 1/2 turn)

- It is important to correctly tension your clipper blades. If they are too loose they will not clip properly or they will clog. If they are too tight the blades will become blunt and may cause overheating.
- Please note as a general rule the least tension you can use to clip the better.

C. Oiling and Cleaning

Before Clipping

- Oil your clipper blades and motor by pouring a thin film of oil:-
 - into the opening(s) on top of the clipper head (see fig.2).
 - onto the clipper blades.
 - between the clipper blades by turning the clipper head sideways.
- Switch on and run your clipper so that the oil spreads.
- Once the clipper blades are well lubricated, switch the clipper off and wipe away any excess oil with a clean dry cloth.

During Clipping

- Regularly brush off loose clipped hair from the blades using the clipper brush to prevent them getting clogged.
- Oil the blades and motor as above, approximately every 5-10 minutes, to stop the clipper blades running dry and the clipper motor overheating.
- We recommend that you only use the specially formulated Wolseley clipping oil. Never use diesel or WD40 as this will damage your blades and your clipper.



D. Changing your Wolseley Clipper Blades for cleaning or replacement.

- Switch off and unplug your clipper from the power supply.
- Unscrew the tension nut and remove it together with the pin and the spring. Keep them in a safe place.
- Carefully remove the clipper blades and wipe each blade clean with dry cloth. Brush away any loose hair between the teeth of the clipper blades. Likewise clean the clipper head.

- To replace the blades fit the upper blade (i.e. the shorter one) on the rectangular pins on the clipper head. The crank roller/block (see fig.3) must fit into the socket of the top blade.
- Place the longer, lower blade onto the retaining lugs.
- Replace the tension pin and carefully holding the clipper blades and tension pin together turn the clipper over. Then replace the tension spring and nut and screw the clipper blades together until they begin to tighten.
- Before clipping, correctly tension and oil your clipper blades (see Section 3 paragraphs B & C).
- Note: Clipper blades are manufactured in pairs and should be used only with their correct pair.

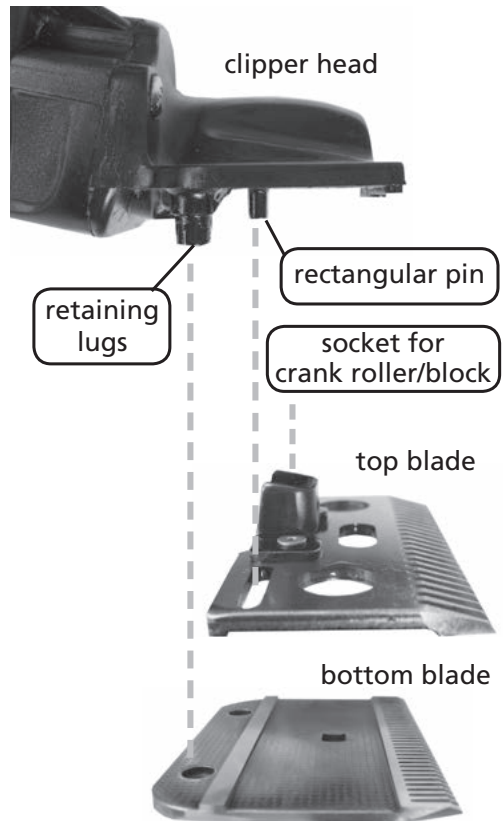

WARNING: When changing or replacing blades on a Wolseley Swift clipper ensure that the crank roller (see fig.3) does not fall out or dislodge. The clipper will not clip successfully without it.

4. Air Filter

- During clipping frequently brush off any loose hair from the air filter to stop the clipper motor from overheating.
- After clipping, remove the air filter by sliding it back, clean it by washing in warm soapy water and replace by sliding back into the designated slot.
- Note: The air filter is positioned at the side or rear of your clipper depending on the model. (see fig.5)

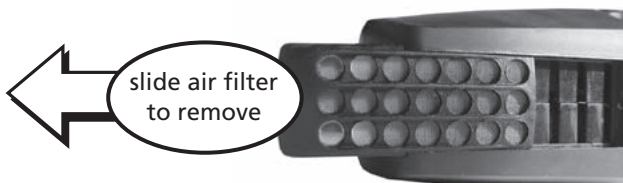

5. Motor Overload Protection

- The motor overload switch is an internal trip-switch to protect the clipper against damage from mechanical or electrical overloading (see fig.5).
- If the clipper is in danger of being damaged the switch will pop out and trip the electrical supply.
- This is usually caused by over-tensioning, lack of oil, blunt blades, blocked air filters, defective motor or faulty electrical supply.
- Disconnect the clipper, identify and rectify the problem (e.g. check the tension, oil and clean the blades, clear air filters, change the blades for a sharper set if blunt).
- Reset the switch by pushing it back in and restarting your clipper.
- If the reset switch fails to stay in after having tripped try an alternative electric supply. If it continues to trip then you will need to return your clipper to the Wolsley Service Department for inspection.
- Never hold the reset button in to prevent it tripping.

6. Blade Sharpening, Clipper Servicing and Repairs

A. Blade Sharpening

- Your Wolsley clipper blades will need regular re-sharpening by our specialist Wolsley Service Department.
- Blunt blades should be removed, cleaned, wrapped and placed in the blister pack provided.
- Using the envelope provided, stamp and post the blades back to Wolsley Service Department (please keep proof of postage).
- Alternately take the blades to your nearest Wolsley clipping services agent.

B. Clipper Servicing and Repairs

- Clippers should be serviced annually by our Wolsley Service Department to prolong their life and to ensure that they run smoothly.
- The service department can also carry out any repairs, which are guaranteed for 6 months.
- **Please note that during the first 2 years all servicing and repairs should only be done by Wolsley otherwise your warranty will be invalidated.**

7. Frequent Clipping Questions

My blades won't cut

- Remove them and clean them as there may be hair between the blades.
- They may be blunt and need replacing with a sharp set.
- The tension might be too slack - consult page 4 to correctly tension.
- If there are lines showing on your horse you may not be overlapping adequately or there may be teeth missing from your blades.

My clipper won't start

- Check to see if the fuse has blown.
- Check to see if the overload button has popped out, identify and rectify the problem before re-setting.
- Check any extension leads being used for faults or damage.
- Check your mains cable for any damage.

My machine is getting too hot

- Check the tensioning of the blades – over tensioning causes the motor to overheat.
- Check that the air vents are free from obstruction
- Ensure that the blades are properly oiled with the correct type of oil.

8. Maintenance and Storage

- When you have finished using the clipper remove the clipper blades, clean and oil them, and store in the Wolsley blade tin.
- Clean and oil the clipper head and store the clipper with the blades in the Wolsley case.
- Store in a dry place out of reach of children.

9. Disposal

- Please dispose of your clipper in the correct manner at a registered recycling facility and not at a landfill site. (more information can be found at www.recyclenmore.co.uk).
- Alternatively, you can contact the retailer who sold you the product or Stockshop Wolsley directly, who will be able to help you dispose of the product.